



PENBERTHY®

Section: 1000
I.O.M.: 1964
Issued: 05/15
Replaces: 05/94

Anoloder

Model GSA for AN-FO (Ammonium Nitrate - Fuel Oil) Blasting

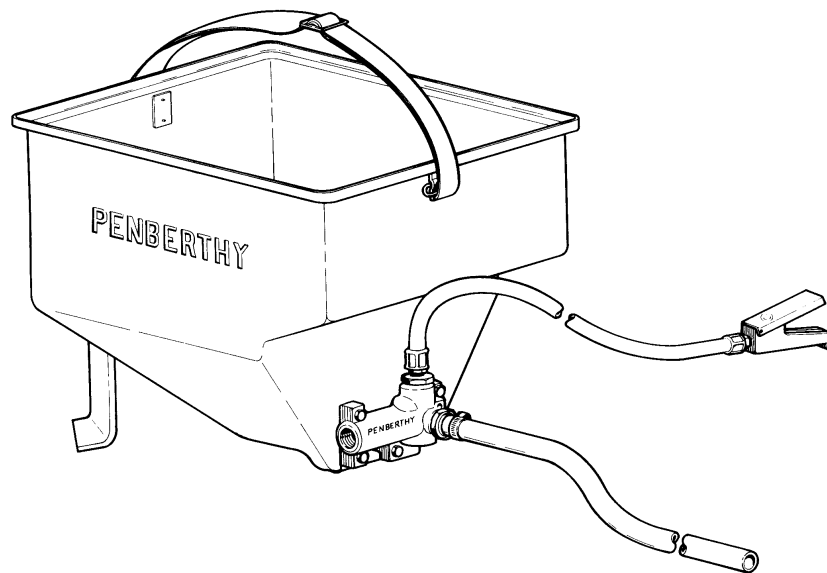

Installation, Operation and Maintenance Instructions

TABLE OF CONTENTS

Product Warranty	iii
1.0 About the Manual	1
2.0 Introduction	1
2.1 System Description	1
2.2 Assembly	2
3.0 Available Models	2
3.1 Maximum Design Pressure Ratings at Operating Temperature Ranges	2
4.0 Inspection	2
5.0 Operation	3
5.1 Testing	3
5.2 Filling and Operating.	3
6.0 Maintenance	3
6.1 Cleaning	4
6.2 Troubleshooting	4
7.0 Disposal at End of Useful Life	4
8.0 Telephone Assistance	5
9.0 Exploded Parts Drawing	6

<u>TABLES AND FIGURES</u>		<u>page</u>
Table 1	Maximum Design Pressure Ratings at Operating Temperature Ranges	2
Table 2	Troubleshooting	4
Figure 1	Exploded Parts Drawing.	6

PENBERTHY PRODUCT WARRANTY

Pentair Valves & Controls Black Mountain warrants its Penberthy products as designed and manufactured by PV&C Black Mountain to be free of defects in the material and workmanship for a period of one year after the date of installation or eighteen months after the date of manufacture, whichever is earliest. PV&C Black Mountain will, at its option, replace or repair any products which fail during the warranty period due to defective material or workmanship.

Prior to submitting any claim for warranty service, the owner must submit proof of purchase to PV&C Black Mountain and obtain written authorization to return the product. Thereafter, the product shall be returned to PV&C in Black Mountain, North Carolina, with freight paid.

This warranty shall not apply if the product has been disassembled, tampered with, repaired or otherwise altered outside of PV&C Black Mountain factory, or if it has been subject to misuse, neglect or accident.

The responsibility of PV&C Black Mountain hereunder is limited to repairing or replacing the product at its expense. PV&C Black Mountain shall not be liable for loss, damage or expenses related directly or indirectly to the installation or use of its products, or from any other cause or for consequential damages. It is expressly understood that PV&C Black Mountain is not responsible for damage or injury caused to other products, buildings, personnel or property, by reason of the installation or use of its products.

THIS IS PV&C BLACK MOUNTAIN'S SOLE WARRANTY AND IN LIEU OF ALL OTHER WARRANTIES, EXPRESSED OR IMPLIED WHICH ARE HEREBY EXCLUDED, INCLUDING IN PARTICULAR ALL WARRANTIES OF MERCHANTABILITY OR FITNESS FOR A PARTICULAR PURPOSE.

This document and the warranty contained herein may not be modified and no other warranty, expressed or implied, shall be made by or on behalf of PV&C Black Mountain unless made in writing and signed by the General Manager or Director of Engineering of PV&C Black Mountain.

INSTALLATION, OPERATION and MAINTENANCE MANUAL FOR PENBERTHY MODEL GSA ANOLODER

1.0 About the Manual

This manual has been prepared as an aid and guide for personnel involved installation or maintenance. All instructions must be read and understood thoroughly before attempting any installation, operation, or maintenance.

Penberthy does not have any control over the manner in which its Anoloder is handled, installed, or used. Penberthy cannot and will not guarantee that the Anoloder is suitable or compatible for the user's specific application.



The Anoloder handles prilled ammonium nitrate/fuel oil mixtures at high pressures. If proper procedures are not followed, the operator could experience a sudden blast of high pressure dust. The operator should wear protective clothing and safety glasses before attempting to operate or perform maintenance on the Anoloder. Failure to do so can result in severe personal injury and property damage.

2.0 Introduction

Penberthy's model GSA is a portable jet loader used in AN-FO blasting. The Anoloder uses a high pressure air stream to educt powder into a discharge flow stream. The powder exits the nozzle at a high velocity and density to fill predrilled holes.

2.1 System Description

The Penberthy Anoloder consists of five basic components. Use the exploded parts view in Section 9.0 as additional reference material.

Ejector- aluminum ejector uses the high pressure air to create a pressure differential. When activated by the remote control valve, the air stream pulls the powder from the container and blows it into predrilled holes.

Canister- plastic canister contains the prilled powder and acts as a hopper to direct the powder flow to the ejector. The canister has a stainless steel fluidizing screen to deter bridging of the powder as it nears the suction port of the ejector. Aluminum legs are bolted to the canister to make it sturdy on level ground.

Remote Control Hose/Valve- aluminum valve allows the operator to control the operating air pressure by pulling the handle. The handle activates the air flow stream by bleeding a portion of the air flow which allows an internal piston to move and open the air orifice in the ejector.

Loading Hose- static-resistant plastic hose directs the air and powder mixture into the drilled hole.

Carrying Strap- canvas strap makes the Anoloder portable. The Anoloder is light enough that most operators can carry the units to various work and powder loading areas.

2.2 Assembly

Attach the control hose to the ejector body by screwing-in the male NPT connection on the end of the air valve control assembly. Attach the black loading hose to the outlet of ejector diffuser using the hose clamp supplied. Penberthy recommends attaching a band of adhesive tape near the end of the loading hose to indicate to the operator that the end of the hose has been reached and the drilled hole is nearly full.

Attach the air hose to the 1" NPT ejector inlet. An adapter fitting (not supplied) for air supply hose connection must be screwed into the 1" NPT connection. A lobe on the body of the ejector near the loading house provides a place to earth ground the ejector using a nut, bolt, and grounding strip (strip not included).



WARNING

Air placement of AN-FO mixtures can result in a hazard due to generation of static electricity. The "conductive" type loading hose supplied with the model GSA Anoloder in conjunction with grounding strips will generally dissipate the static charges as they are generated. To ensure safe operation applicable codes and mining regulations must be followed without exception. Neglecting to compensate for potential static electricity buildup could result in an unexpected explosion, resulting in severe personal injury and property damage.

3.0 Available Models

All Anoloder models have a 1" female NPT air line connection to the ejector. The loading hose is available in a standard 25ft length or 100 ft length. Penberthy Anoloders are available in three different sizes. The model size determines the loading hose size. The GSA 5/8" has a 5/8" diameter hose. The GSA 3/4" has a 3/4" diameter hose. The GSA 1" has a 1" diameter hose.

3.1 Maximum Design Pressure Ratings at Operating Temperature Ranges

Part Description	Material	Maximum Temperature	Maximum Pressure
Body	Aluminum	225°F [107°C]	110 psig [760 kPaG]
Loading Hose	Conductive PVC	140°F [60°C]	120 psig [830 kPaG]

Table 1

4.0 Inspection



Upon receipt of a Penberthy Model GSA Anoloder, check all components carefully for damage incurred in shipping. If damage is evident or suspected, do not attempt installation. Notify carrier immediately and request damage inspection.

Penberthy Model GSA Anoloder is comprised of (1) canister with attached carrying strap and ejector, (1) remote control valve/hose assembly, (1) loading hose, (1) clamp, (1) grounding bolt, and (1) grounding nut. Confirm that the delivered Model GSA Anoloder: 1) matches the appropriate size and model on the purchase order, and 2) accommodates the actual operating conditions at the installation site.

5.0 Operation

Only qualified, experienced personnel who are familiar with AN-FO blasting equipment and thoroughly understand the implications of the tables and all of the instructions should operate the Anoloder. The Anoloder is operated with 30 to 110 psig, (210 to 760 kPaG), compressed air. For maximum performance keep pressure losses between air main and unit to a minimum. Dirt, mud, and other foreign matter must be kept out of the air supply line.

5.1 Testing

Safety glasses, gloves and protective clothing should be worn when testing the Model GSA Anoloder. Connect the air hose to the Anoloder and squeeze the hand control valve two or three times to test valve operation. The unit can be expected to load properly if air blows freely out loading hose.

5.2 Filling and Operating

Pour the AN-FO into the canister to within a few inches of the top (approximately 25 lbs), or up-end the entire bag and leave it in the container. Insert loading hose into drill hole to predetermine the length of hose needed to reach the bottom of the hole. Back the hose out of the hole one to four feet from the bottom.

SAFETY INSTRUCTIONS

Improper technique could result in a sudden blow-back of AN-FO from the drilled hole during loading. Operator should stand to one side of the drilled hole, never directly in front. Failure to avoid hole openings could result in irritating and potentially harmful AN-FO material covering the operator.

The operator should stand one to four feet from the drill hole when grasping the loading hose. Increasing this stand-off distance beyond six feet will decrease the loading density, while decreasing this distance to one foot may cause some of the AN-FO particles to be blown out of drill hole.

6.0 Maintenance

Use only qualified, experienced personnel who are familiar with this type of equipment and thoroughly understand all the instructions in this manual. Ammonium nitrate is a corrosive and hygroscopic compound which can quickly clog pneumatic loading equipment. Maintenance is an important factor in ensuring safe Anoloder operation.

6.1 Cleaning

Empty any AN-FO left in the Anoloder canister. Wash down the Anoloder and other exposed equipment with water. Pour water into the canister and use the control valve to blow air through the ejector until all water has been removed. A screen is provided in the air inlet of the ejector to prevent foreign matter from entering the ejector. The air strainer should be removed and cleaned regularly.

In some cases it will be advisable to clean the ejector body and parts with naphtha (petroleum spirits) at regular intervals to minimize corrosion. The ejector should only be dismantled in a proper maintenance area, using the following procedure:

- ◆ unscrew ejector bonnet nut
- ◆ remove spring, piston, and piston O-ring
- ◆ remove air strainer retainer ring and air strainer screen
- ◆ snap off diffuser shroud and unscrew ejector diffuser one-half turn
- ◆ clean body and parts with naphtha (petroleum spirits)
- ◆ dry parts with a clean cloth and blow out body with compressed air
- ◆ tighten diffuser, reassemble, and test operation

6.2 Troubleshooting

Problem	Cause	Cure
Anoloder cannot be turned on or off	plugged piston valve	take ejector apart and clean as described in previous section
	plugged control valve	manipulate control valve piston, wash in water, and blow out with air
Anoloder operated but no AN-FO exits loading hose	plugged ejector inlet or loading hose	clean Anoloder as described in previous section - be sure air lubricator has been removed from air hose
Sharply reduced loading rate	plugged air strainer	remove air strainer and clean
	dirt in ejector body	take ejector apart and clean as described in previous section
	partially plugged ejector inlet or loading hose	clean Anoloder as described in previous section - be sure air lubricator has been removed from air hose
	air pressure at ejectors is too low	increase air pressure to recommended range (Section 5.0)

Table 2

7.0 Disposal at End of Useful Life

Penberthy's Model GSA Anoloders are used in a variety of fluid applications. By following the appropriate federal and industry regulations, the user must determine the extent of preparation and treatment the Model GSA Anoloder must incur before its disposal. A Material Safety Data Sheet (MSDS) may be required before disposal services accept certain components.

Metal, glass and polymers should be recycled whenever possible. Refer to order and PV&C - Black Mountain Material Specification sheets for materials of construction.

8.0 Telephone Assistance

If you are having difficulty with your Model GSA Anoloder, contact your local Penberthy distributor. . So that we may assist you more effectively, please have as much of the following information available as possible when you call:

- Model #
- Name of the company from whom you purchased the Model GSA Anoloder
- Invoice # and date
- Process conditions (pressure, flow rates, tank shape, etc)
- A brief description of the problem
- Trouble shooting procedures that failed

If attempts to solve your problem fail, you may request to return your Model GSA Anoloder to the factory for intensive testing. You must obtain a Return Authorization (R.A.) number from PV&C Black Mountain before returning anything. Failure to do so will result in the unit being returned to you without being tested, freight collect. To obtain an R.A. number, the following information (in addition to that above) is needed:

- Reason for return
- Person to contact at your company
- "Ship To" address

There is a minimum charge of \$75.00 for evaluation of non-warranty units. You will be contacted before any repairs are initiated should the cost exceed the minimum charge. If you return a unit under warranty, but is not defective, the minimum charge will apply.

9.0 Exploded Parts Drawing

Recommended Spare Parts
Ejector Repair Kit (E-Kit)

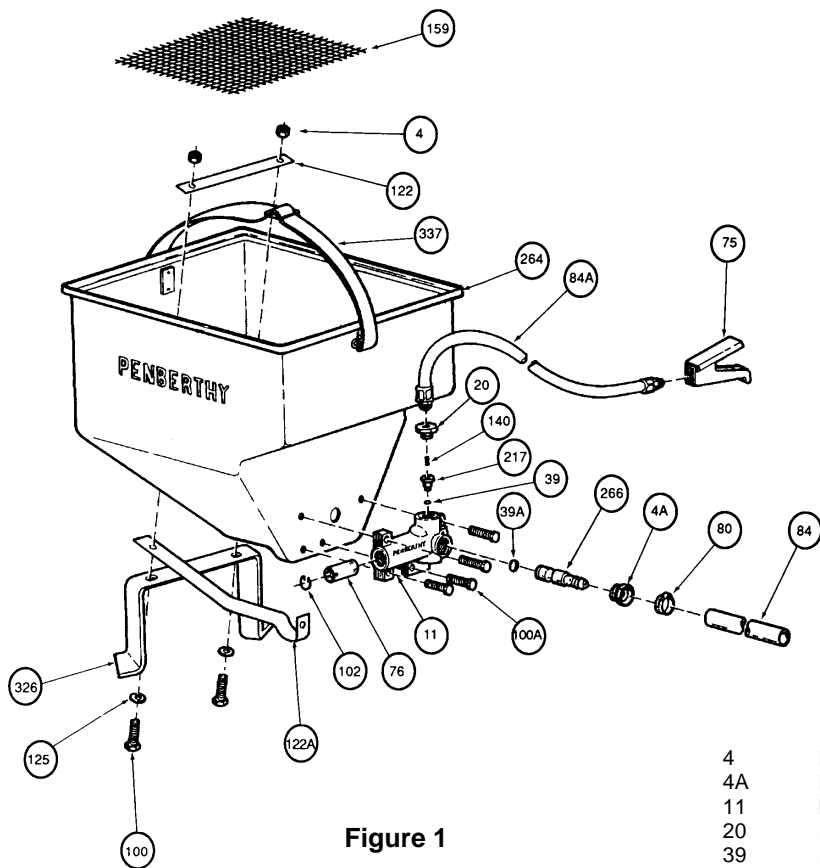

Figure 1

- 4 Nut
- 4A Nut
- 11 Body
- 20 Ejector Bonnet
- 39 Piston O-Ring
- 39A Cartridge O-Ring
- 75 Valve
- 76 Strainer
- 80 Clamp
- 84 Loading Hose
- 84A Control Hose
- 100 Leg Screw
- 100A Ejector Screw
- 102 Clip
- 122 Grounding Strip (in)
- 122A Grounding Strip (out)
- 125 Washer
- 140 Piston Spring
- 159 Canister Screen
- 217 Piston
- 264 Canister
- 266 Cartridge
- 326 Support
- 337 Strap



Pentair Valves & Controls
953 Old U.S. Highway 70, Black Mountain, North Carolina 28711
Phone: 828-669-5515
FAX: 828-669-4017
Printed in USA
Part No. 14868-009

© 2015 Pentair Valves & Controls, Black Mountain, All Rights Reserved