

PENBERTHY TECHNICAL DATA

automatic injector

This technical bulletin includes general information about Penberthy Automatic Injectors plus specific details for individual unit selection. Used primarily as boiler feed pumps, Penberthy Automatic Injectors are used in numerous other applications for pumping liquids and discharging at high pressure and temperature.



The Injector

The Injector may be defined as a boiler feeding pump, utilizing the velocity and condensation of a jet of steam from the boiler to lift and force into the same boiler a jet of water many times the weight of the original jet of steam.

Although they are generally considered as boiler feed pumps, injectors are also often used on other applications where hot water under high pressure is desired.

ADVANTAGES

The injector offers definite advantages over mechanically operated pumps when cold water make-up is used to feed boilers. Some of these advantages are:

- 1 Warm water is fed into the boiler without the necessity of preheating the water.
- 2 It is not dependent upon an outside source of power.
- 3 Unit is compact, has no mechanically operated parts and requires no foundation or floor space.
- 4 First cost and maintenance are low.
- 5 Operating steam is condensed and returned to the boiler resulting in a thermal efficiency of nearly 100%.
- 6 Dependable in operation.

Operating Principle of Penberthy Automatic Injectors

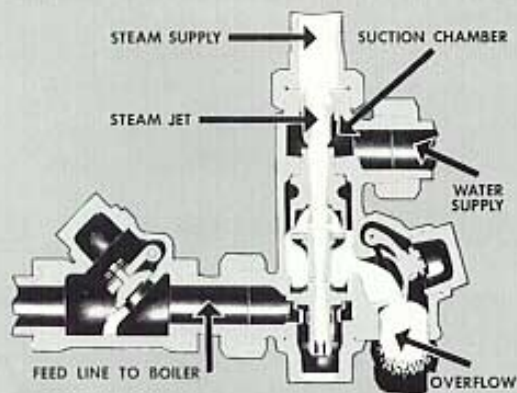

When steam supply valve is opened, steam passes through steam jet into suction chamber, proceeds through suction jet and out of the overflow. Steam, which attains a velocity of approximately 2500 ft per second as it leaves the steam jet, entrains the air in suction chamber and creates a vacuum.

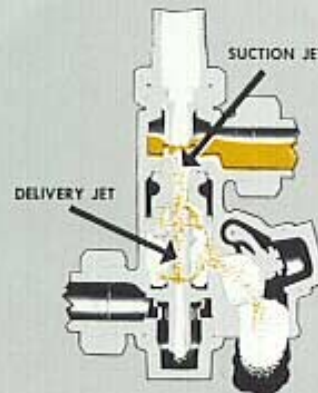

The vacuum created in suction chamber begins to draw in water from supply line. The water is now entrained by the steam and a high velocity mixture of water and steam passes through the suction jet and out of the overflow.

The Company

Since its organization in 1886, the Penberthy Manufacturing Co.* has been well known as a leading manufacturer of injectors. As a result of its superior basic injector design, continued improvements in performance, manufacturing methods and standard of quality, Penberthy leadership in the injector field has been universally recognized for many years. Penberthy injectors and service parts may be

purchased from any one of the thousands of jobber and dealer representatives in all principal cities and countries of the world. Their knowledge of the various applications of the Penberthy injector, covering many years of experience, assures prospective users that they will obtain intelligent engineering sales service.

PENBERTHY AUTOMATIC INJECTORS

Automatic Restarting

All Penberthy injectors are of the automatic restarting type. If the established flow of water from an injector to the boiler is interrupted temporarily by the admission of air into the suction line or by a jolt causing the overflow valve to open, the injector will automatically reestablish flow without the necessity of regulating any valves.

Feeds Warm Water to Boiler

Penberthy injectors feed water into the boiler at a temperature of from 130°F to 212°F depending upon the steam pressure and temperature of the supply water. By throttling the water supply line, feed water temperatures up to 212°F can be obtained under most conditions of operation.

Design

Injectors are designed so as to give well-balanced operation against the greatest possible range of steam pressure, water temperature and suction lift and to maintain satisfactory

performance for a long period of service. Designs are the result of years of experience with injector applications.

Injector connections have uni on tailpipes permitting quick removal from the line.

all parts are easily removed for cleaning or replacement and are precision made to assure interchangeability in the field. Workmanship is highest quality. Years of manufacturing has resulted in the training of skilled craftsmen and the development of advanced production methods.

Material

Injectors are of all bronze construction with special bronze alloys being used for suction and delivery jets to resist wear.

Inspection and Testing

All injectors are tested at the factory on actual boiler installations, assuring that injectors will meet all performance claims as specified for the various models.

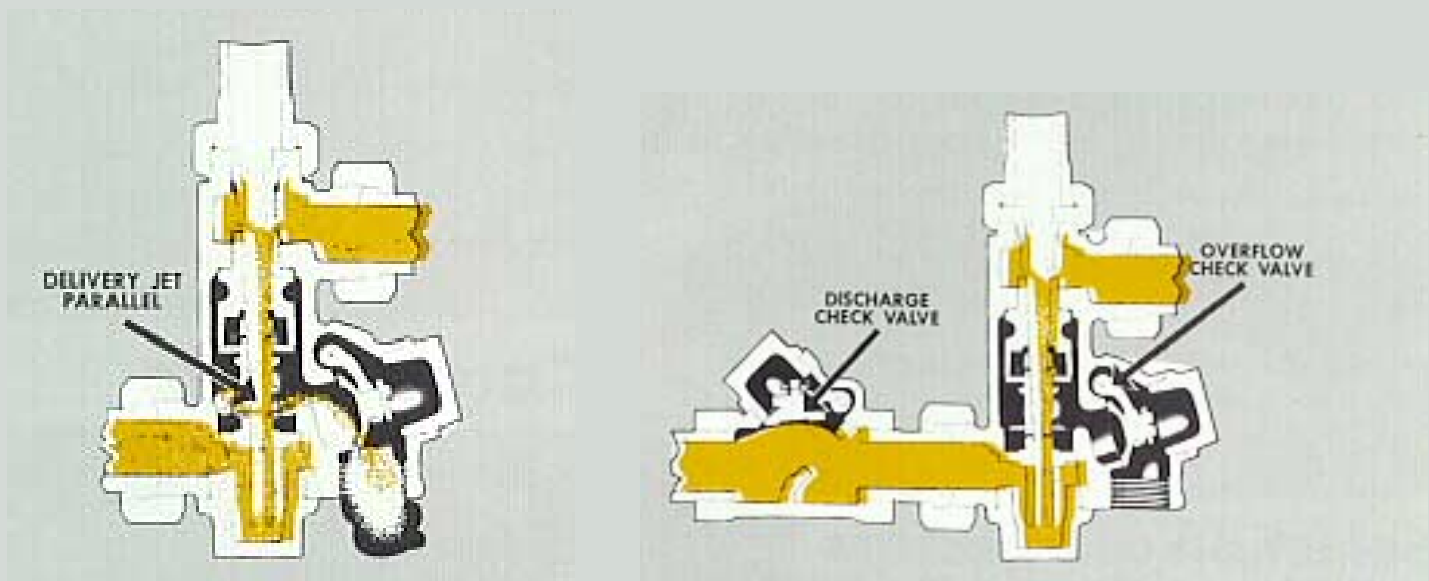

When the amount of steam and water reach the proper proportion, the steam gradually condenses as the mixture advances through injector. Upon reaching delivery jet parallel the mixture is fully condensed.

The energy contained in the water passing through delivery jet is sufficient to build up a pressure, greater than the boiler pressure, causing water to flow through the discharge check valve into the boiler. When flow into the boiler is established the overflow valve closes automatically and prevents the entrance of air which would disrupt operation of injector. Total operating cycle requires only a few seconds.

Applications

Injectors are installed as auxiliary equipment on power boilers, package steam generators, locomotive boilers and heating boilers that are required by many industries such as:

Manufacturing Industries: Food processing, chemical, oil production and refining, agriculture, mining, lumber, etc.

Service Industries: Pressing and dry cleaning, vulcanizing, dairies, laundries, public utilities, transportation,

Uses

Uses for injectors can be classified generally as follows:

Stand-by Boiler Feed Pump Service

Injectors provide boilers, which are already equipped with mechanically operated boiler feed pumps, with a reliable low cost secondary means of feed water supply. Many boiler manufacturers supply Penberthy Injectors as original equipment on their steam boilers.

Primary Boiler Feed Pump Service

Boilers not provided with mechanical feed water pumps can depend upon injectors to function satisfactorily as the sole source of feed water supply.

Preheating Make-up Water

On applications where the water supply pressure exceeds the boiler steam pressure, injectors may be used to heat the water before injection into the boiler, avoiding the disadvantage of cold water striking hot boiler surfaces.

Injecting Feed Water Treatment Compounds

Suitably diluted mixtures of boiler feed water treatment compounds are picked up and injected into the boiler without difficulty.

High Pressure and Temperature Water Supply

Injectors may be used as a source for obtaining a supply of hot water under high pressure for washing floors, containers, machine parts, etc. When used for this purpose the discharge nozzle must be sized to suit the injector capacity. See page 10 for details of installation.

Selection of Injectors

Models or types of injectors are available from which to select an injector that will operate satisfactorily and efficiently under virtually any field conditions that may be encountered in steam plant practice with steam pressures up to 250 pounds per square inch.

Required Information

Injector can be properly selected by considering the following facts relating to the operating conditions under which the injectors will be required to work:

1. Lowest and highest operating steam pressure carried by the boiler
2. Vertical distance that the supply water must be lifted, if the water supply is below the injector, and the horizontal distance from the water intake to the injector.
3. The supply water pressure if the water is taken from the city mains or from elevated tanks.
4. The temperature of the supply water.
5. The maximum rate of evaporation of water from the

Capacity

The size of the injector to be selected depends principally upon the rate at which the boiler is called upon to evaporate water. It should be chosen so that it will deliver at least 30% (preferably 50 to 100%) more water than the expected maximum evaporation rate of boiler. Catalog horsepower ratings are based upon supplying approximately 75% more than the rate of evaporation of a boiler operating at full rating, or between 7 and 8 gallons per boiler horsepower. Reference to injector performance tables will indicate that the capacity of an injector will vary, depending upon the operating steam pressure, suction lift, suction water temperature or a combination of these conditions. Unless an injector is already operating at limiting conditions, its capacity can be reduced by regulating the water supply line valve to

Catalog Data

By referring to performance and dimensional information given on the following pages, the injector that will best suit the capacity and operating conditions of the application can be readily selected and specified. In the event of unusual operating conditions or doubt as to proper selection, our engineering department is available to offer recommendations and suggestions.

PENBERTHY Standard INJECTORS

**FOR SUCTION LIFT APPLICATIONS
WITH STEAM PRESSURE
FROM 25 TO 140 PSI**

**SUITABLE FOR STEAM PRESSURES
UP TO 250 PSI WITH
WATER PRESSURE SUPPLY**

Penberthy Standard Injectors are available in two body styles and 8 sizes with screwed connections from 3/8" to 2 1/2" pipe size, having capacities as given in performance tables on page 6. They are designed to meet the requirements of most applications and will operate satisfactorily within the following range of operating conditions:

Suction Lift Applications

Start Low: 25 psi steam pressure with 3 ft lift and 74°F water

Work High: up to 140 psi steam pressure with 3 ft lift and 74°F water

Lift Water: 20 ft at 60 to 80 psi steam pressure with 74°F water

Maximum temperature of Suction Water: 3 ft lift and steam pressures as follows:

- 120°F at 60 to 80 psi
- 115° at 100 psi
- 105°F at 120 psi
- 90°F at 140 psi

Water Pressure Supply Applications

When water under pressure is connected directly to the injector suction, Penberthy Standard Injectors can be operated at steam pressures up to 250 psi. At steam pressures of 100 psi or more, capacities are substantially increased and water supply must be regulated with extra care. On applications where steam pressures are below 100 psi, Penberthy "Low Pressure" Injectors are recommended.

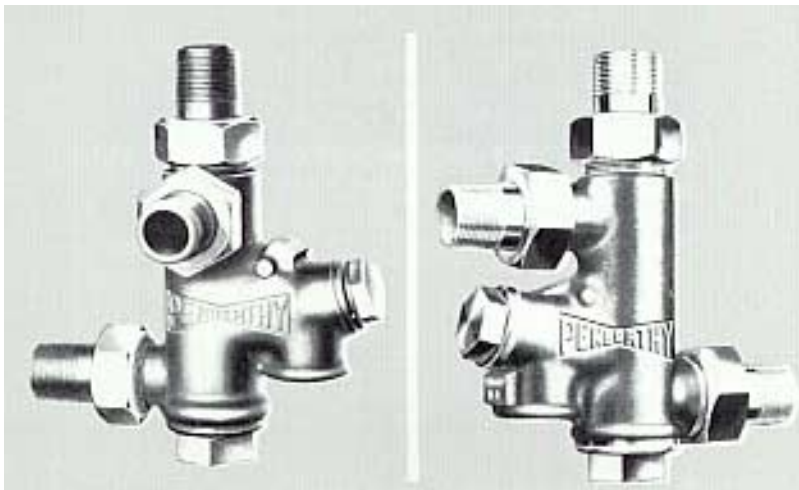

STOCK MODEL
SUCTION LEFT – DELIVERY BACK

SUCTION FRONT
DELIVERY BACK

STOCK MODEL SUPPLIED UNLESS OTHERWISE SPECIFIED

SIZE NO.	*BOILER HORSE-POWER RATING	PIPE SIZE CONN. (IN.)	SHIPPING WEIGHT BOXED (LB)
OO-21	12	3/8	2 1/2
AA-21	25	1/2	3 1/2
BB-21	50	3/4	5 1/2
CC-21	85	1	8
DD-21	150	1 1/4	12
EE-23	250	1 1/2	25
FF-23	425	2	39
GG-21	600	2 1/2	75

*Boiler horsepower ratings based on supplying approximately 7 gallons of water per horsepower per hour with 3 ft suction lift and 80 psi steam pressure.

Each injector is supplied with all bronze pipe strainer one size larger than injector connection for installation at end of suction pipe.

Size 00-21 injector is provided with relief valve to facilitate starting at lower steam pressures.

Size 00-21 injector is supplied with two small strainers for insertion in the steam and water supply union connections.

IMPORTANT

Injectors deliver their maximum capacity and operate to better satisfaction in the intermediate zone of their pressure operating range. When selecting an injector, in order to be assured of best possible performance, refer to Pages 5, 7 and 8 covering operating characteristics of the Penberthy Standard, High Pressure and Low Pressure Injectors.

See Page 6 for Dimensions

See Page 9 for Installation Data and page 11 for Repair Parts

PERFORMANCE OF PENBERTHY STANDARD INJECTORS

Suction Lift Operation

Capacities in Gallons per Hour at Various Suction Lifts-74°F Water Temperature							
SIZE NO.	LIFT IN FEET	STEAM PRESSURES--PSIG					
		40	60	80	100	120	140
OO-21	3	60	70	80	75	65	55
	8	50	65	75	70	61	...
	12	45	55	70	65	55	...
	16	36	50	65	60	45	...
	20	...	45	60	53
AA-21	3	150	175	180	165	155	150
	8	142	165	157	145	135	...
	12	135	155	135	133	120	...
	16	120	140	125	110
	20	...	110	110
BB-21	3	300	350	350	310	295	280
	8	290	300	300	270	250	230
	12	260	270	265	240	220	...
	16	...	240	235	215
	20	...	220	210
CC-21	3	540	585	585	550	520	480
	8	520	550	540	490	470	460
	12	420	425	420	400	390	...
	16	...	405	390	380
	20	...	360	300
DD-21	3	780	940	950	915	840	800
	8	760	900	870	780	720	705
	12	730	750	750	630	570	...
	16	...	580	555	525
	20	...	440	440
EE-23	3	1440	1800	1800	1740	1620	1500
	8	1300	1710	1710	1600	1460	1320
	12	1200	1500	1500	1450	1400	...
	16	...	1220	1200	1150
	20	...	1020	1000
FF-23	3	2200	2520	2940	2880	2640	2500
	8	2200	2520	2400	2160	1920	...
	12	2040	2280	2160	1920
	16	...	1920	1800	1560
	20	...	1560	1400
GG-21	3	3140	3600	4200	4100	3750	3550
	8	3100	3600	3430	3100	2700	...
	12	2900	3250	3000	2700
	16	...	2740	2550	2200
	20	...	2200	2000

Pressure Supply Operation

Capacities in Gallons per Hour with 12 PSIG Water Pressure Supply at 74°F Temperature							
SIZE NO.	STEAM PRESSURES--PSIG						
	80	100	120	140	160	200	250
OO-21	80	95	100	115	115	110	105
AA-21	180	210	225	255	255	245	230
BB-21	350	405	440	490	490	475	445
CC-21	585	675	730	820	820	790	745
DD-21	950	1095	1190	1330	1330	1285	1205
EE-23	1800	2070	2250	2520	2520	2430	2285
FF-23	2940	3385	3675	4120	4120	3970	3735
GG-21	4200	4830	5250	5880	5880	5670	5335

Capacities shown are maximum amount injector can pump at steam pressures indicated. If flow exceeds amounts shown, due to excessive water supply pressure, valve in water supply line can be regulated to provide correct flow.

Capacities are reduced if injectors are required to handle water at higher than normal temperature. When operating with a 3 ft lift at the limiting temperature, for a given steam pressure, capacities are reduced approximately as follows:

Water Temperature	90°F	100°F	110°F	120°F
Reduction in capacity in %	10	12	15	20

Dimensions of Penberthy Standard and High Pressure Injectors

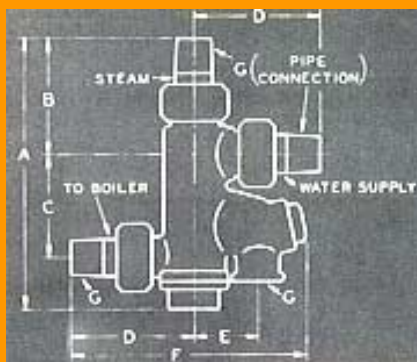

SIZE NO.	DIMENSIONS IN INCHES						
	A	B	C	D	E	F	G
OO	4 3/4	2	1 3/4	2 3/8	1 1/4	4 1/2	3/8
AA	5 7/8	2 3/8	2 3/8	2 5/8	1 1/4	5 1/8	1/2
BB	7 1/8	2 3/4	2 7/8	3 1/8	1 5/8	5 3/4	3/4
CC	8 1/8	3	3 5/8	3 3/8	1 7/8	6 5/8	1
DD	9 3/4	3 5/8	4 1/4	4 1/4	2 1/4	7 7/8	1 1/4
EE	13 1/4	4 3/4	5 3/8	4 3/4	3	9 5/8	1 1/2
FF	15 1/8	5 1/4	6 7/8	5 1/4	3 5/8	11 1/4	2
GG	17 5/8	5 7/8	8 1/2	6 5/8	4 1/2	14 1/2	2 1/2

PENBERTHY High Pressure INJECTORS

FOR SUCTION LIFT APPLICATIONS WITH STEAM PRESSURES FROM 50 TO 200 PSI

Penberthy High Pressure Injectors are available in two body styles and 8 sizes with screwed connections from 3/8" to 2 1/2" pipe size having capacities as given in performance table. At the same operating pressure, they use less steam than "Standard" injectors permitting the handling of warmer supply water and higher suction lift as indicated by their design range given below:

Start Low: at 50 psi steam with 3 ft lift and 74° water

Work High: up to 200 psi steam pressure with 3 ft lift and 74° water

Lift Water: 20 ft with steam pressures from 80 to 120 psi and 74°F water

Maximum Temperature of Suction Water with 3 ft lift and at steam pressures as follows:

- 120°F at 120 psi
- 115°F at 140 psi
- 105°F at 170 psi
- 85°F at 200 psi

SIZE NO.	*BOILER HORSE-POWER RATING	PIPE SIZE CONN. (IN.)	SHIPPING WEIGHT BOXED (LB)
OO-326	12	3/8	2 1/2
AA-328	27	1/2	3 1/2
BB-330	50	3/4	5 1/2
CC-332	90	1	8
DD-334	140	1 1/4	12
EE-336	275	1 1/2	25
FF-338	450	2	39
GG-340	650	2 1/2	75

*Boiler horsepower ratings based on supplying approximately 7 gallons of water per horsepower per hour with 3 ft suction lift and 140 psi steam pressure.

Each injector is supplied with all bronze pipe strainer one size larger than injector connection for installation at end of suction pipe.

Sizes OO-326 through DD-334 are provided with relief valve to facilitate starting at the lower steam pressures.

Size OO-326 injector is supplied with two small strainers for insertion in the steam and water supply union connections

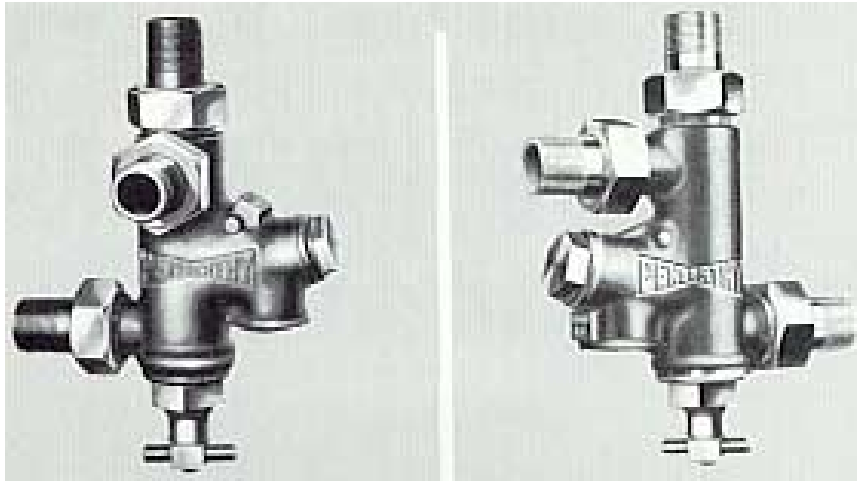

STOCK MODE
SUCTION LEFT - DELIVERY BACK

SUCTION FRONT
DELIVERY BACK

STOCK MODEL SUPPLIED UNLESS OTHERWISE SPECIFIED

Capacities in Gallons per Hour at Various Suction Lifts - 74° Water Temperature									
SIZE NO.	VERTICAL LIFT IN FEET	STEAM PRESSURES--PSIG							
		60	80	100	120	140	160	180	200
OO-326	3	54	68	84	89	91	85	81	76
	8	50	61	74	77	78	72	68	...
	12	43	52	63	66	66	61
	16	39	44	54	56	56
AA-328	3	130	150	180	200	210	200	190	180
	8	120	135	158	174	181	170	161	...
	12	104	115	135	148	153	144
	16	94	97	115	126	130
BB-330	3	238	300	367	390	400	375	357	332
	8	220	270	323	339	344	318	303	...
	12	190	231	275	288	292	270
	16	171	195	234	246	248
CC-332	3	450	510	640	680	670	640	600	540
	8	416	459	563	592	576	544	510	...
	12	360	393	480	503	489	391
	16	324	331	409	428	415
DD-334	3	600	820	930	1020	1080	1000	960	900
	8	555	738	818	887	929	850	816	...
	12	480	631	697	755	788	720
	16	432	533	595	643	670
EE-336	3	1220	1550	1890	2010	2050	1920	1830	1710
	8	1128	1395	1663	1748	1763	1632	1555	...
	12	976	1193	1417	1487	1497	1382
	16	878	1007	1209	1266	1271
FF-338	3	2000	2530	3080	3290	3350	3140	3000	2790
	8	1850	2277	2710	2862	2881	2669	2550	...
	12	1600	1948	2310	2435	2446	2261
	16	1440	1644	1971	2073	2077
GG-340	3	2750	3470	4225	4500	4600	4300	4100	3800
	8	2540	3100	3700	3900	3950	3660	3500	...
	12	2200	2670	2170	3330	3350	3100
	16	1950	2250	2700	2840	2800
20	...	1840	2200	2300	

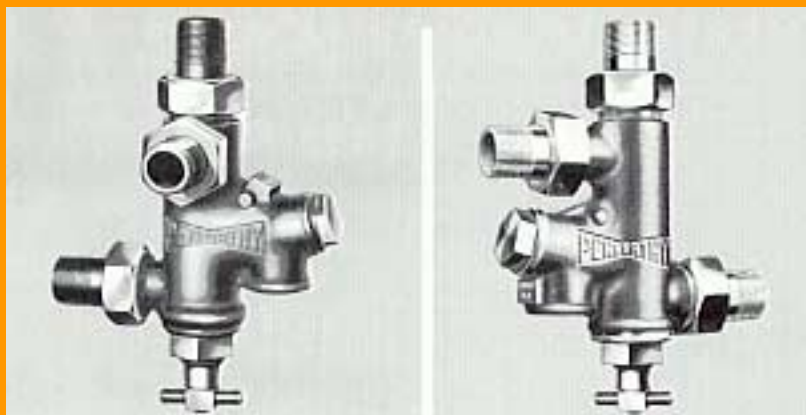

**STOCK MODEL
SUCTION LEFT - DELIVERY BACK**

**SUCTION FRONT
DELIVERY BACK**

STOCK MODEL SUPPLIED UNLESS OTHERWISE SPECIFIED

PENBERTHY Low Pressure INJECTORS

**FOR STEAM PRESSURES FROM 15 TO 100
PSI WITH 3 FT SUCTION LIFT OR WATER
PRESSURE SUPPLY**

Designed to operate under conditions of relatively low boiler pressure using cold water with a 3 ft maximum suction lift or water pressure supply connected directly to suction connection, injector is ideal as a feed water pump for process steam boilers used in vulcanizing shops, dairies, laundries or for clothes pressing machines.

Available in 2 body styles and 7 sizes with screwed connections from 3/8" to 2" pipe size and having capacities as indicated in performance table. Injector uses the same body as the "Standard" and "High Pressure" Injectors.

SIZE NO.	*BOILER HORSE-POWER RATING	PIPE SIZE CONN. (IN.)	SHIPPING WIEGHT BOXED (LB)
OO-526	12	3/8	2 1/2
AA-528	25	1/2	3 1/2
BB-530	50	3/4	5 1/2
CC-532	85	1	8
DD-534	125	1 1/4	12
EE-536	240	1 1/2	25
FF-538	400	2	39

Capacities in Gallons per Hours 3 Ft Lift 74°F Water Temperature					
Size No.	Steam Pressures--PSIG				
	20	40	60	80	100
OO-526	55	80	75	65	55
AA-528	125	180	170	160	150
BB-530	270	350	330	305	280
CC-532	490	585	565	520	480
DD-534	720	900	880	800	720
EE-536	1350	1700	1650	1500	1350
FF-538	2300	2900	2800	2350	2300

*Boiler horsepower ratings based on supplying approximately 7 gallons of water per horsepower, per hour with 3 ft suction lift and 40 lbs steam pressure.

Each injector is supplied with all bronze pipe strainer one size larger than injector connection for installation at end of suction pipe.

Sizes OO-526 through DD-534 are provided with relief valve to facilitate starting at the lower steam pressures.

Size OO-526 injector is supplied with two small strainers for insertion in the steam and water supply union connections.

When operated with water pressure supply, capacities shown in table will be increased approximately 20%.

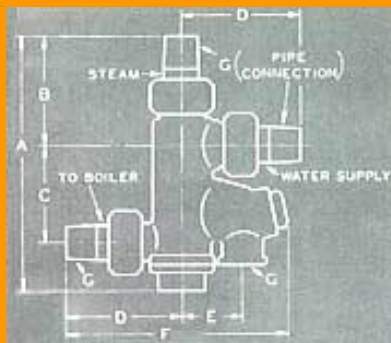

SIZE NO.	DIMENSIONS IN INCHES						
	A	B	C	D	E	F	G
OO	4 3/4	2	1 3/4	2 3/8	1 1/4	4 1/2	3/8
AA	5 7/8	2 3/8	2 3/8	2 5/8	1 1/4	5 1/8	1/2
BB	7 1/8	2 3/4	2 7/8	3 1/8	1 5/8	5 3/4	3/4
CC	8 1/8	3	3 5/8	3 3/8	1 7/8	6 5/8	1
DD	9 3/4	3 5/8	4 1/4	4 1/4	2 1/4	7 7/8	1 1/4
EE	13 1/4	4 3/4	5 3/8	4 3/4	3	9 5/8	1 1/2
FF	15 1/8	5 1/4	6 7/8	5 1/4	3 5/8	11 1/4	2

See Page 6 for Dimensions

See Page 9 for Installation Data and pate 11 for Repair Parts

INSTALLATION INSTRUCTIONS

FOR SUCTION LIFT

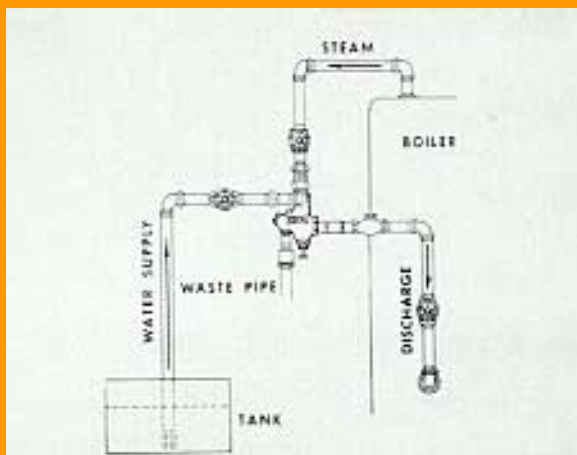

Penberthy Injectors are used with any type of water supply. To obtain the best possible results the following points should be considered.

1. The steam pipe should be an independent line, the same size as the injector connection point and connected to the boiler at the highest possible point.
2. If injector operates on a suction lift, the water supply pipe should be one size larger than the injector connection except on very short lifts. On long suction lifts, a pipe 2 sizes larger with a foot valve installed at end of pipe is recommended. A globe valve, the full size of supply pipe, should be installed in this line and the strainer which is provided each injector should be attached at the end. It is very important that the water supply pipe connection including the valve stem packing be free from leaks.

FOR WATER PRESSURE SUPPLY

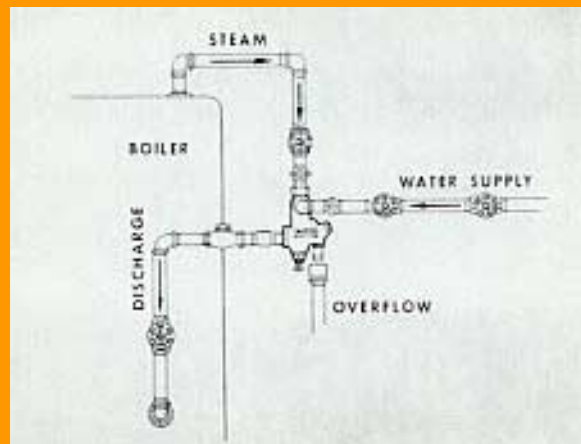

Penberthy Injectors are used with any type of water supply. To obtain the best possible results the following points should be considered.

3. If injector water supply is taken from city water mains or an overhead tank, better regulation of water may be obtained if two globe valves are installed in the water supply line. The valve nearest the injector is used to regulate the water supply while the second valve is adjusted permanently to provide the most desirable pressure reduction.
4. The delivery pipe should be the same size as the injector connection or larger if desired. A swing check valve and a globe valve should be installed in this line, which should be as direct and as free from elbows as the installation will permit.

OPERATION

To Start: Fully open the water supply valve and the discharge valve. Next, fully open the steam valve. If water continues to come out of overflow connection, throttle the water supply valve until it stops. On low pressure operation it may be necessary to throttle the water supply valve in order to establish injector operation. On high pressure operation it is satisfactory to throttle the steam valve until the water supply pipe is primed, but under all other conditions the steam valve should

be wide open and regulation of flow governed by the water supply valve.

To Stop: Close the steam valve. The water supply valve need not be closed unless supply water is under pressure. The discharge line valve needs to be closed only as a precautionary measure as the check valve will prevent back flow from the boiler.

See Page 9 for Installation Data and page 11 for Repair Parts

INJECTOR INSTALLATION FOR PRESSURE WASHING

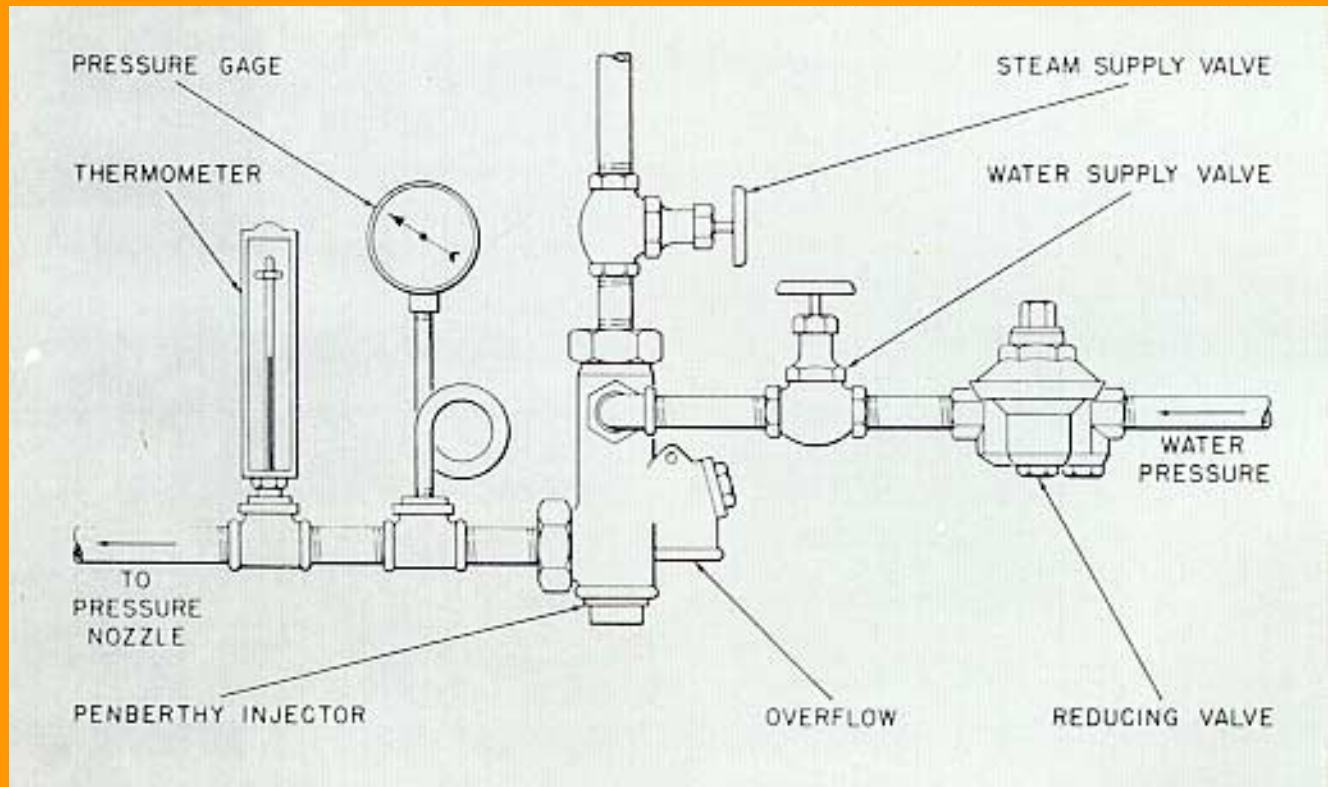

Installed as shown above, injector will produce a high pressure hot water discharge up to 200°F.

Balance between injector capacity and total nozzle discharge capacity is important.

With proper size nozzle, and using dry steam for operation, discharge pressures equal to or even greater than boiler pressures are obtainable.

When operating, steam valve should be open wide and water supply valve throttled to suit discharge flow.

For ordinary conditions, reducing valves on the water supply line are not necessary, however if a reducing valve is used, its capacity should be checked to ascertain that the flow will be sufficient for proper operation.

It is important to use dry steam.

To start operation: Open water supply valve, then open steam valve wide; next, throttle water supply valve until injector quits spilling at overflow.

REPAIR PARTS

Standard Injector	OO-21	AA-21	BB-21	CC-21	DD-21	EE-23	FF-23	GG-21
High Pressure Injector	OO-326	AA-326	BB-330	CC-332	DD-334	EE-336	FF-338	GG-340
Low Pressure Injector	OO-526	AA-526	BB-530	CC-532	DD-534	EE-536	FF-538	

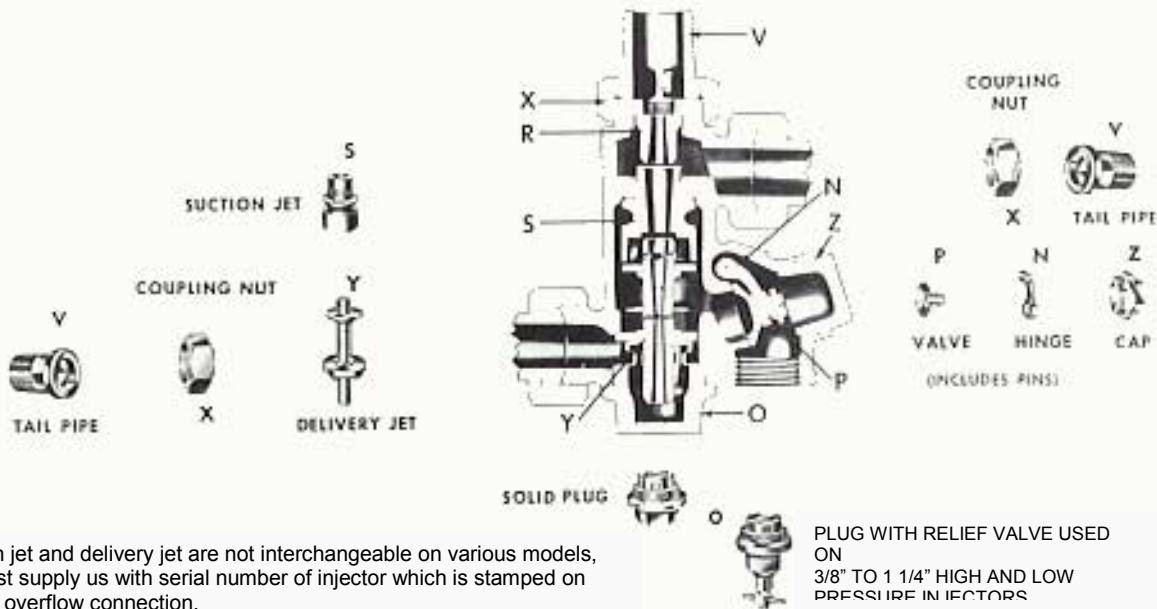

Steam jet, suction jet and delivery jet are not interchangeable on various models, therefore you must supply us with serial number of injector which is stamped on nameplate above overflow connection.

PLUG WITH RELIEF VALVE USED ON 3/8" TO 1 1/4" HIGH AND LOW PRESSURE INJECTORS



BRASS STRAINERS

These large-capacity strainers are furnished with every injector to prevent passageways in the jets from becoming stopped up by foreign matter. Sizes 2" and larger are the flat type shown at right.

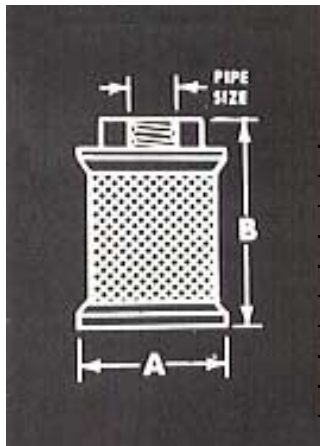

DIMENSIONS IN INCHES			
Pipe size	A	B	Wire Mesh
3/8	1 11/16 dia	2 1/4	30
1/2	1 11/16 dia	2 1/4	30
3/4	1 11/16 dia	2 5/16	30
1	1 7/8 dia	2 9/16	16
1 1/4	2 3/16 dia	2 9/16	16
1 1/2	2 1/2 dia	2 11/16	16
2*	3 5/8 dia*	1 3/4*	1/8 holes
2 1/2*	4 3/5 dia*	1 13/16*	1/8 holes
3*	4 1/4 sq*	1 13/16*	1/8 holes

